



Thermostatic Mixing Valve w/ Integral Check Valves

Forged Brass Valve

w/ G1 Union Connections

Outlet Temperature Range 95° - 120°F

Lead Free

Max Operating Pressure: 150 PSI

Certified to NSF/ANSI 61 & 372

Body (H-70000W) Certified to ASSE 1017, CSA B125.3



ITEM#	Connection	SIZE (in)	CTN	CASE	A	B	C	D
H-71202W-CAN	F1807 PEX	1/2	1	10	5.30	5.72	3.15	1.56
H-71203W-CAN	F1807 PEX	3/4	1	10	5.25	5.67	3.11	1.56
H-72202W-CAN	FIP	1/2	1	10	5.50	6.25	3.38	1.56
H-72203W-CAN	FIP	3/4	1	10	5.50	6.25	3.38	1.56
H-72204W-CAN	FIP	1	1	10	5.56	6.38	3.45	1.56
H-73202W-CE-CAN	F1960 PEX	1/2	1	10	5.50	6.50	3.50	1.56
H-73203W-CE-CAN	F1960 PEX	3/4	1	10	5.75	7.00	3.75	1.56
H-74202W-CAN	MIP*	1/2	1	10	5.22	5.60	3.06	1.56
H-74203W-CAN	MIP*	3/4	1	10	5.26	5.66	3.12	1.56
H-74204W-CAN	MIP*	1	1	10	5.69	6.50	3.52	1.56
H-75202W-CAN	CxC*	1/2	1	10	5.15	5.44	3.00	1.56
H-75203W-CAN	CxC*	3/4	1	10	5.61	6.44	3.52	1.56
H-75204W-CAN	CxC*	1	1	10	5.80	6.69	3.63	1.56
H-76202W-CAN	Push**	1/2	1	10	6.00	7.13	4.07	1.56
H-76203W-CAN	Push**	3/4	1	10	6.25	7.38	3.94	1.56
H-78202W-CAN	Press	1/2	1	10	5.75	6.56	3.56	1.56
H-78203W-CAN	Press	3/4	1	10	6.00	7.06	3.75	1.56
H-78204W-CAN	Press	1	1	10	6.00	7.06	3.75	1.56

*Certified to ASSE 1070

**Certified to ASSE 1061



Hot Inlet Temperature Range	120 - 185°F (49 - 85°C)
Cold Inlet Temperature Range	39 - 80°F (4 - 27°C)
Outlet Temperature Stability ¹	± 5°F (3°C)
Working Pressure Range	30 - 150 psi (2 - 10 bar)
Minimum Temperature Differential Between Hot Supply and Mixed Outlet ²	20°F (11°C)
Maximum Inlet Pressure Ratio ³	2:1
Minimum Flow Rate <i>for optimal performance</i>	0.5 gpm (2 L/min)
C _v	2.5
¹ . As tested in accordance with ASSE 1017. ² . Required minimum temperature difference between the mixed outlet and the hot supply to enable the valve to function correctly and ensure automatic reduction of outlet flow in the event of cold supply failure. ³ . Maximum permitted variation in Hot/Cold or Cold/Hot supply pressure in order to control the outlet temperature to within ± 5°F. Excessive fluctuation in supply pressures may cause outlet temperature to be outside of specified tolerance.	

Designed for residential or commercial use. Threaded ends comply with ANSI B1.20.1. Solder joint temperature ratings are per ASME B16.18 Annex A for 95-5 solder. Other solder materials have lower pressure/temperature limits. Do not silver braze or overheat valves when soldering.

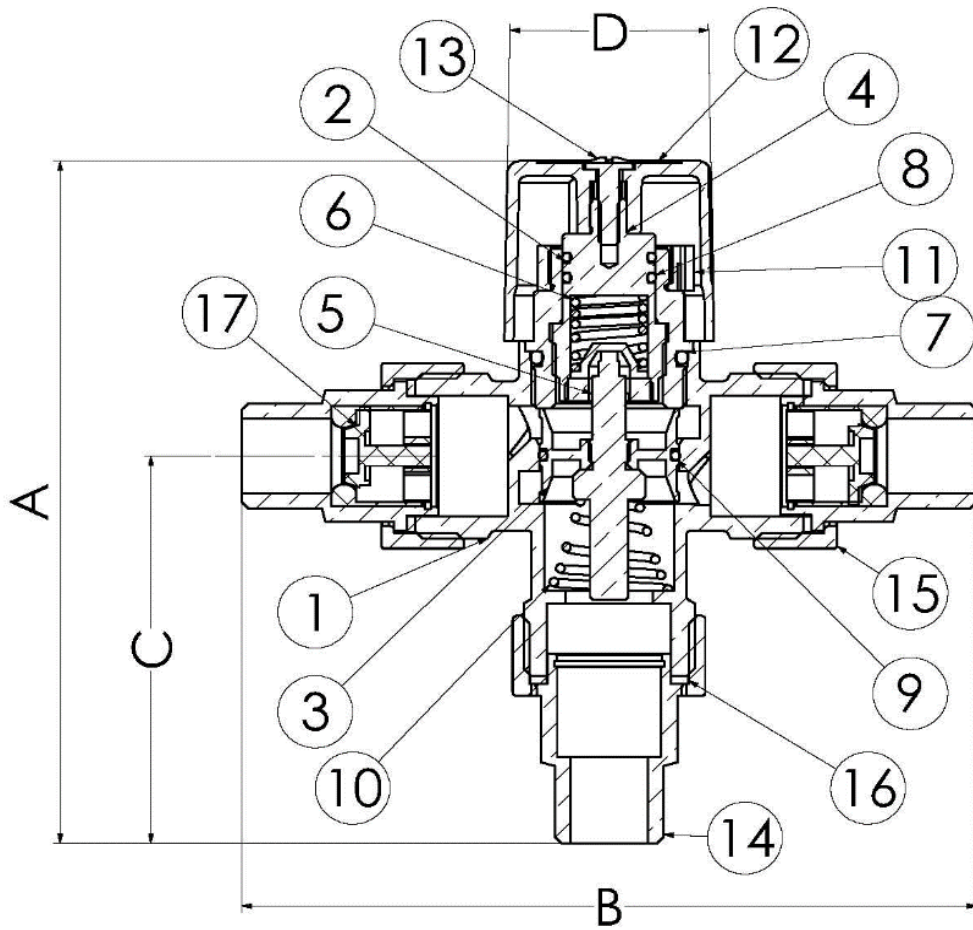

Flow Rate by Pressure Differential

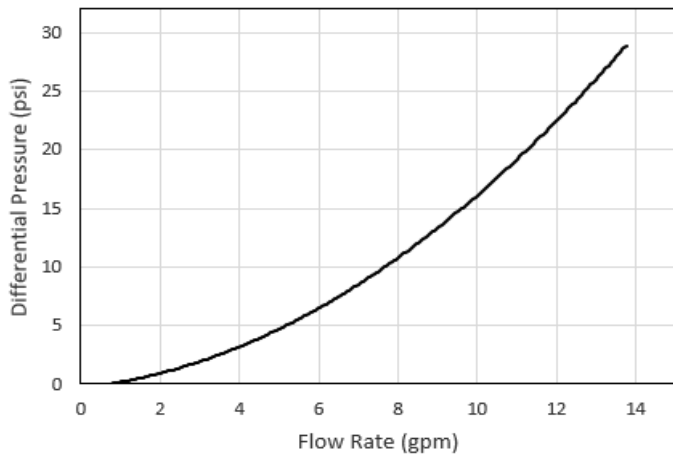

NO.	DESCRIPTION	MATERIAL
1	Body	Brass
2	End Cap	Brass
3	Piston	Brass HCP
4	Spindle	Brass
5	Element	Wax Filled Copper
6	Spindle Spring	Stainless Steel
7	O-ring	EPDM
8	O-ring	EPDM
9	O-ring	EPDM
10	Spring	Stainless Steel
11	Locking Ring	Plastic
12	Adjustment Cap	Plastic
13	Locking Screw	Stainless Steel
14	SWT Fitting	Brass
15	Union Nut	Brass
16	Gasket	EPDM
17	Check Valve	Plastic