

THIS SPACE FOR DESIGNER/ENGINEER APPROVAL

Job/Customer _____	Date _____	Contractor _____
Model Specified _____	Qty _____	Approved By _____
Designer/Engineer _____	Date _____	Contractor's PO# _____
Submitted by _____	Date _____	Other _____

1015 Series

Heavy Pattern Brass Gate Valves

Hard Seat

IPS

Ratings: 300 WOG / 150 WSP

Standard brass products are certified to
NSF/ANSI 61

ITEM #	SIZE	CTN	CASE	A	B	C	D
10150	1/4	10	60	1/4	1 11/16	2 7/8	2
10151	3/8	10	60	3/8	1 11/16	2 7/8	2
10152	1/2	10	60	1/2	1 11/16	2 7/8	2
10153	3/4	10	80	3/4	1 3/4	3 5/16	2 1/8
10154	1	5	60	1	2 1/8	3 7/8	2 1/2
10155	1 1/4	5	40	1 1/4	2 1/4	4 5/8	2 11/16
10156	1 1/2	5	30	1 1/2	2 7/16	5	3 1/8
10157	2	2	12	2	2 11/16	6	3 1/2
10158	2 1/2	1	6	2 1/2	3 11/16	7 7/8	4
10159	3	1	6	3	4	8 13/16	4 3/8
10160	4	1	4	4	4 1/2	9 7/8	5



NO.	DESCRIPTION	MATERIAL
1	Wheel Nut	Steel
2	Name Plate	Aluminum
3	Handwheel	Cast Iron
4	Packing Nut	Brass
5	Gland Ring	Brass
6	Gland Packing	Graphite
7	Bonnet	Brass
8	Packing	Fibre "H"
9	Stem	Brass
10	Lock Nut	Brass
11	Disc	Brass
12	Body	Brass

Webstone
VALVE INNOVATION

Quality and Commitment Since 1954

www.webstonevalves.com P: (800) 225-9529 F: (800) 336-5133

Webstone product specifications in U.S. customary units are approximate and are provided for reference only. Webstone reserves the right to change or modify product design, construction, specifications or materials without prior notice and without incurring any obligation to make such changes and modifications on Webstone products previously or subsequently sold.

1015spec_08152014

THIS SPACE FOR DESIGNER/ENGINEER APPROVAL

Job/Customer _____	Date _____	Contractor _____
Model Specified _____	Qty _____	Approved By _____
Designer/Engineer _____	Date _____	Contractor's PO# _____
Submitted by _____	Date _____	Other _____

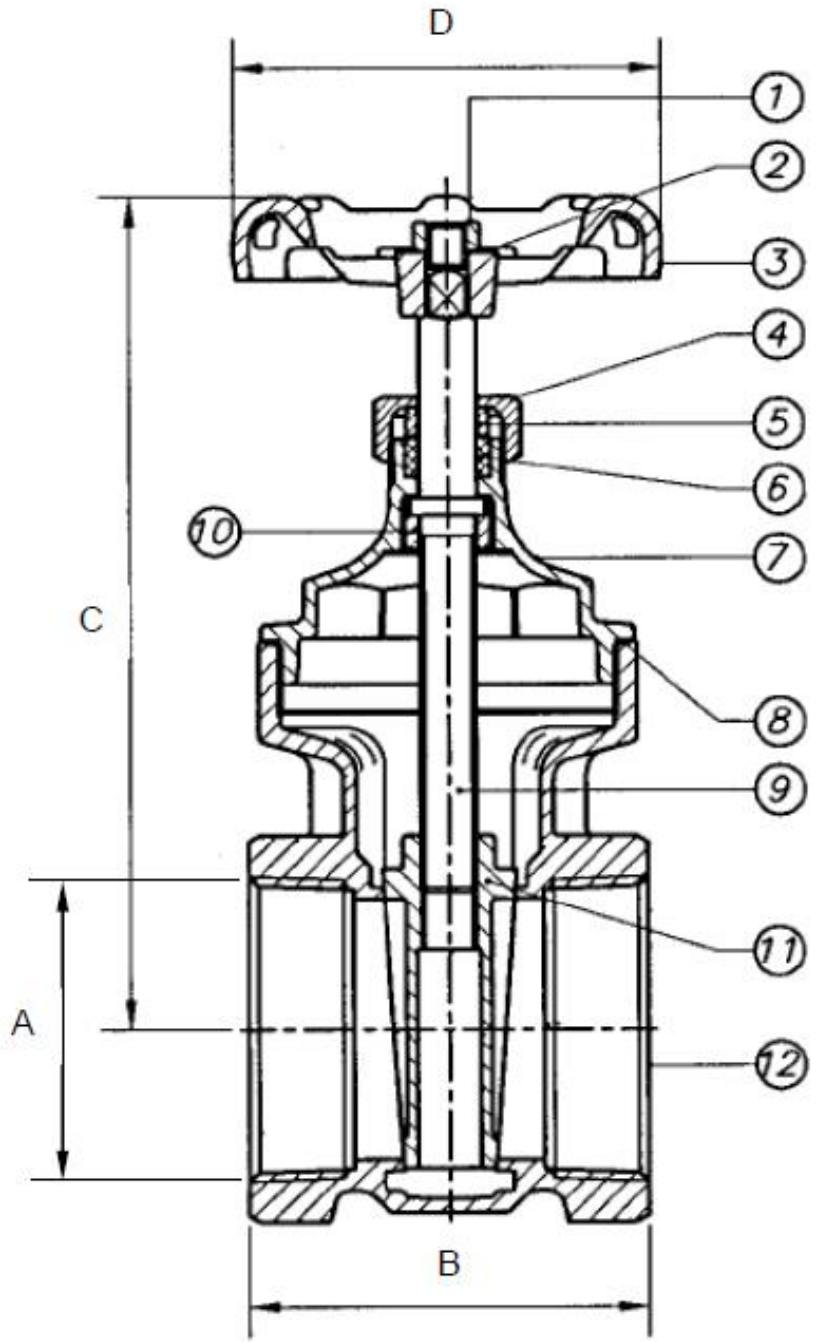

Webstone
VALVE INNOVATION

Quality and Commitment Since 1954

www.webstonevalves.com P: (800) 225-9529 F: (800) 336-5133

Webstone product specifications in U.S. customary units are approximate and are provided for reference only. Webstone reserves the right to change or modify product design, construction, specifications or materials without prior notice and without incurring any obligation to make such changes and modifications on Webstone products previously or subsequently sold.