

**THIS SPACE FOR DESIGNER/ENGINEER APPROVAL**

Job/Customer _____	Date _____	Contractor _____
Model Specified _____	Qty _____	Approved By _____
Designer/Engineer _____	Date _____	Contractor's PO# _____
Submitted by _____	Date _____	Other _____

## 10141W Series

**Full Port Forged Brass Uni-Flange Ball Valves  
w/ Detachable Rotating Flange, Conical Inlet  
& Multi-Function Hi-Flow Hose Drain  
Adjustable Packing Gland w/ Nuts & Bolts  
Female PP-RCT Metric Socket x Rotating Flange  
Manufactured for use with all PP-R & P-RCT Piping Systems  
Max. Operating Pressure: 600 PSI\*\*  
ISO 9001 - Patented Technology**



Lead free products are certified to NSF/ANSI 61 & NSF/ANSI 372

LEAD FREE ITEM #	METRIC PIPE SIZE	SIZE *	CTN	CASE	A	B	C	D	E	F	G	H	I	J
101413WHV	25	3/4"	1	20	3/4	3 9/16	2 13/16	4	7/16	5/8	1 1/2	2 11/16	4 1/8	2 3/4
101414WHV	32	1"	1	20	1	3 3/4	2 5/8	4	7/16	5/8	1 1/2	2 11/16	4 1/8	2 3/4
101415WHV	40	1 1/4"	1	10	1 1/4	4 7/16	2 15/16	5 3/4	7/16	5/8	1 1/2	2 11/16	4 1/8	3 1/4
101416WHV	50	1 1/2"	1	10	1 1/2	5 3/16	3 1/2	5 3/4	7/16	5/8	1 1/2	2 11/16	4 1/8	3 1/2
101417WHV	63	2"	1	10	1 1/2	5 3/8	3 1/2	5 3/4	7/16	5/8	1 1/2	2 11/16	4 1/8	3 3/8



NO.	DESCRIPTION	MATERIAL
1	FLANGED BODY	BRASS
2	END CAP	BRASS w/ PP-RCT
3	SEATS	PTFE
4	BALL	BRASS HCP
5	STEM	BRASS
6	STEM SEAL	PTFE
7	PACKING GLAND	BRASS
8	HANDLE NUT	STAINLESS STEEL
9	HANDLE JACKET	VINYL
10	DRAIN VALVE SEATS	PTFE
11	DRAIN VALVE BALL	BRASS HCP
12	DRAIN VALVE STEM	BRASS
13	DRAIN VALVE STEM SEAL	PTFE
14	DRAIN VALVE HANDLE	ENAMEL COATED ALUMINUM
15	DRAIN VALVE HANDLE SCREW	BRASS
16	DRAIN VALVE CAP, WASHER & STRAP	BRASS w/ EPDM
17	ROTATING FLANGE	BRASS
18	ROTATING FLANGE RING	STAINLESS STEEL
19	FLANGE BOLTS & NUTS	STEEL ZP

\*PP-R Sockets are manufactured based on metric units of measurement. Imperial nominal diameter is provided as reference only. 101417WHV (2" only) is a Reduced Port Valve. \*\*Valve seat/body maximum pressure rating at 100 F. Overall valve pressure rating is determined by intended operating conditions and limitations specific to the system design.



Quality and Commitment Since 1954

www.webstonevalves.com · P: (800) 225-9529 · F: (800) 336-5133

Webstone product specifications in U.S. customary units are approximate and are provided for reference only. Webstone reserves the right to change or modify product design, construction, specifications or materials without prior notice and without incurring any obligation to make such changes and modifications on Webstone products previously or subsequently sold.

10141Wspec\_122815

**THIS SPACE FOR DESIGNER/ENGINEER APPROVAL**

Job/Customer _____	Date _____	Contractor _____
Model Specified _____	Qty _____	Approved By _____
Designer/Engineer _____	Date _____	Contractor's PO# _____
Submitted by _____	Date _____	Other _____

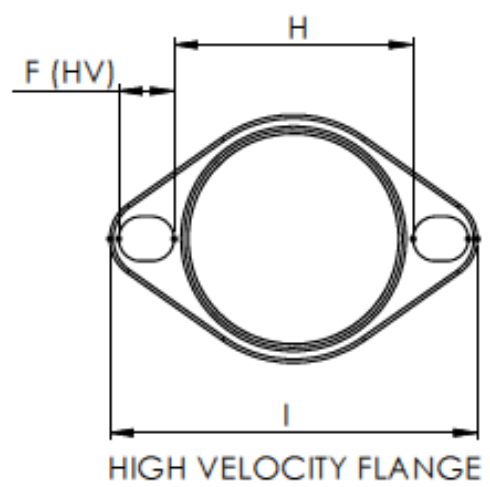
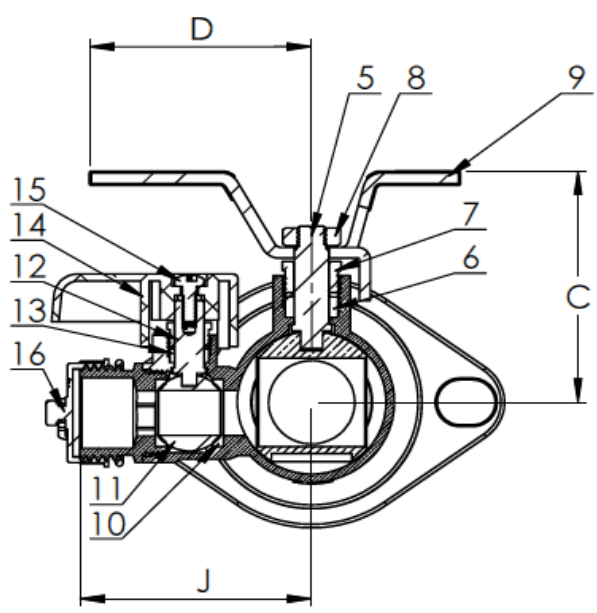
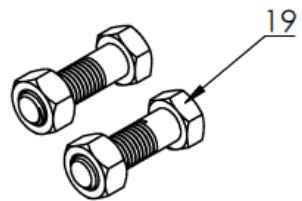
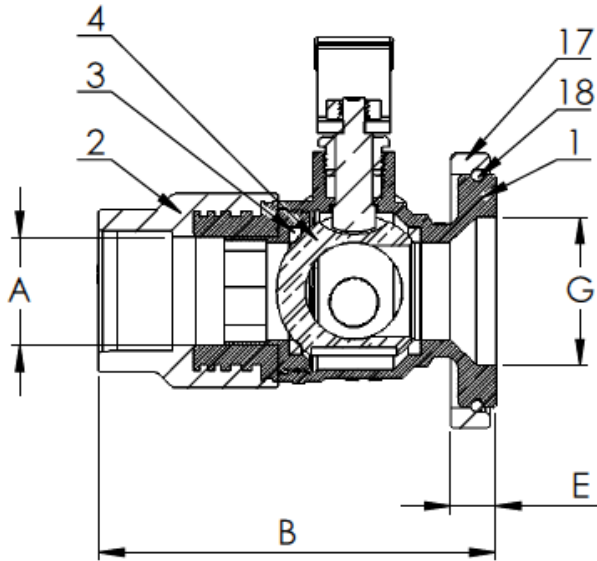

**Specifications:** Designed for residential, commercial or industrial use with water, oil or gas. This approved Webstone valve is actuated by a blowout proof stem and features an adjustable packing gland. Socket end dimensions are in accordance with ASTM F 2389 Metric Series. HV models fit both standard and high velocity pumps.



Quality and Commitment Since 1954

www.webstonevalves.com · P: (800) 225-9529 · F: (800) 336-5133

Webstone product specifications in U.S. customary units are approximate and are provided for reference only. Webstone reserves the right to change or modify product design, construction, specifications or materials without prior notice and without incurring any obligation to make such changes and modifications on Webstone products previously or subsequently sold.